



# Installation Instructions

## 818206

### Cat Back Exhaust

#### 24-26 GM Silverado / Sierra

#### 6.2L Engine and O.E.M Active exhaust



Installation requires moderate mechanical skill. If this job is beyond your abilities, seek the services of a qualified technician.

If you do not understand any part of these instructions, please call Flowmaster Technical Support at (866) 464-6553 for assistance.

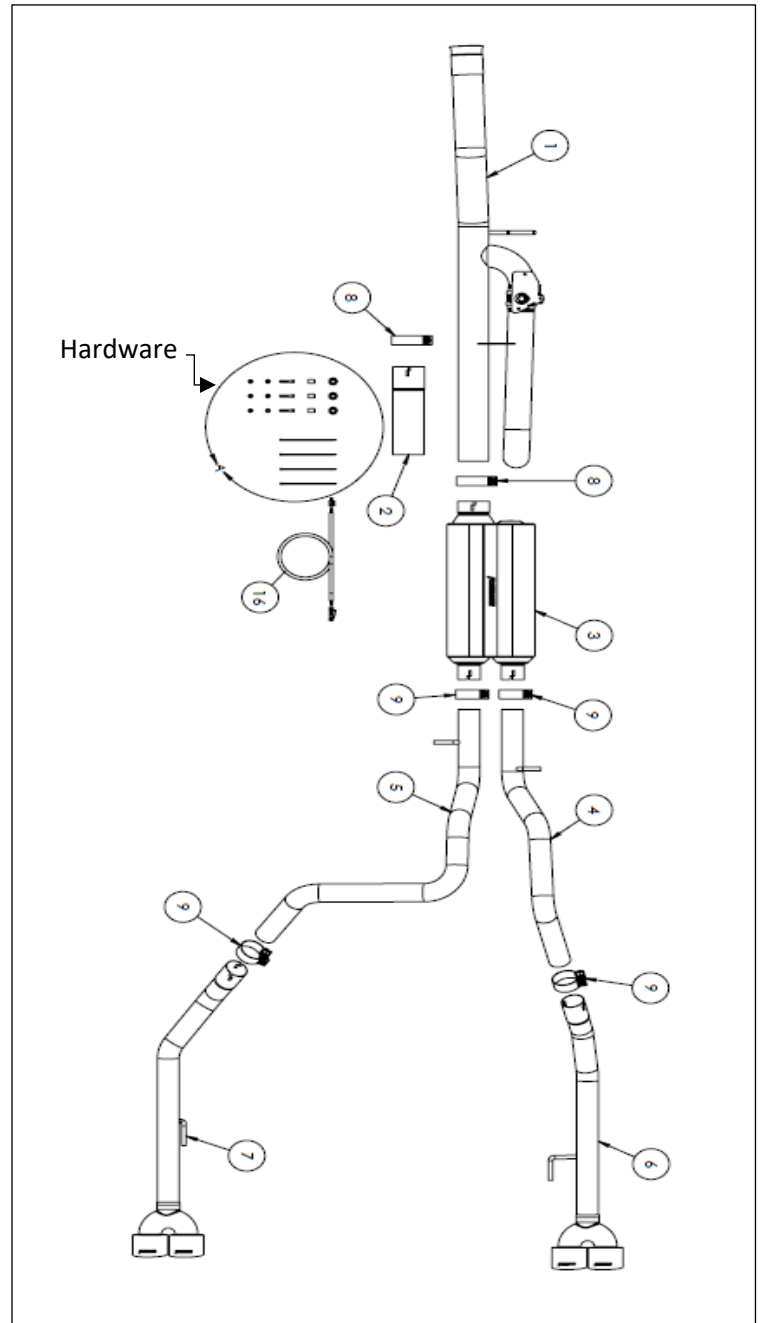
Apply penetrating oil generously to clamps, fasteners, pipes, and hanger rods for ease of disassembly.

### REVIEW THE INSTRUCTIONS & VERIFY THE KIT CONTENTS

Take a moment to read and understand these instructions before installing your Flowmaster exhaust kit.

ITM#	Part #	Description	Qty.
1	36089S	Muffler Inlet Pipe	1
2	36065S	Extension Pipe	1
3	8535562-Z	Muffler	1
4	86559S	Right Front Tail Pipe	1
5	86560S	Left Front Tail Pipe	1
6	86561S	Right Rear Tail Pipe	1
7	86562S	Left Rear Tail Pipe	1
8	MC350BS	3.5" Band Clamp	2
9	MC250BS	2.5" Band Clamp	4
10	HW503	1/2" Push Nut	3
11	HW557	1/2" O.D X 3/4" Spacer	3
12	HW270	1/4-20 X 1.5 Button Head Bolt	3
13	HW332	1/4" Lock washer	3
14	HW101	1/4-20 Nut	3
15	HW545	Cable Tie	4
16	EV706	Valve Harness Extension	1

Use the parts drawing and list to identify components and verify your kit's contents. In the unlikely event that any parts are missing, please contact Flowmaster Technical Support for replacements.



## Vehicle Compatibility

Model Year: 2024 - 2026

Make: GM

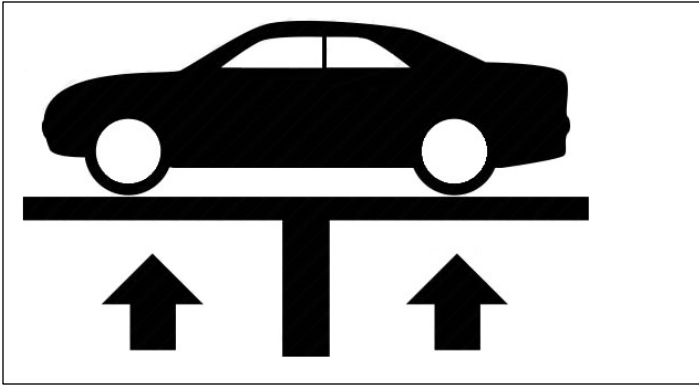
Model: 1500

Engine: 6.2L V8 With OEM Active Exhaust and Tip  
Bezels at Bumper

**Will Not Work With:**

\* 5.3L Engine

\* ZR2 / Bison (with "No" exhaust tip bezels at bumper)



### BEFORE STARTING:

Raise the vehicle to a minimum of eighteen inches. A floor hoist is ideal. If no hoist is available, we strongly urge the use of axle stands as a safety measure. **Please read and understand these instructions and disclaimer in their entirety before attempting installation.**

**CAUTION! WORK ONLY ON A LEVEL SURFACE. USE JACKS /JACK STANDS OF SUFFICIENT CAPACITY TO LIFT AND SUPPORT YOUR VEHICLE. NEVER WORK UNDER A VEHICLE SUPPORTED BY A FLOOR OR BUMPER JACK**

### Removing the OEM Exhaust:

**NOTE: Cutting the factory exhaust is recommended but not necessary. Please read and follow all the instructions before attempting to install this exhaust system.**

### Removing the OEM Muffler Assembly

1. Apply penetrating oil to each rubber Hanger on the exhaust.
2. Unplug the Exhaust valve Harness and unclip the harness from the exhaust bracket.
3. Support the exhaust assembly before making cuts or removing any rubber hangers.
4. Cut the Right tail pipe at the location in **Fig. 1/ Fig.2**
  - Measure from the weld on the passenger side tail pipe just past the rear Y section and make a witness mark at 2.0 inches. **Fig.2**
  - Wrap masking tape around the pipe at the mark to use as a straight edge for making a clean cut.
  - Cut the pipe at the mark, following the tape edge as you go.
  - Remove the 15mm bolt from the right tail pipe isolators and remove the tail pipe and isolator. **Fig.1/2**

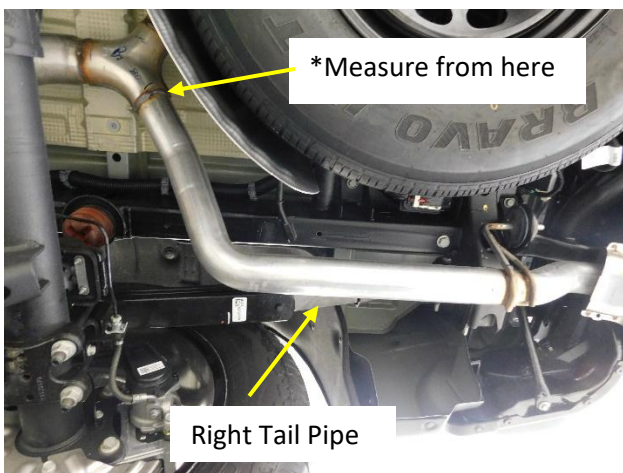


Figure.1

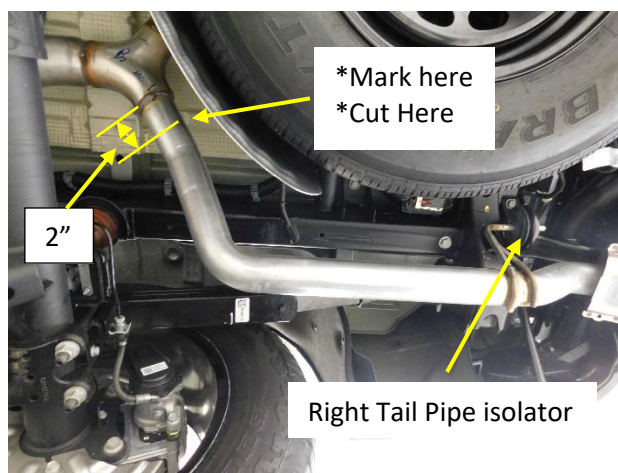
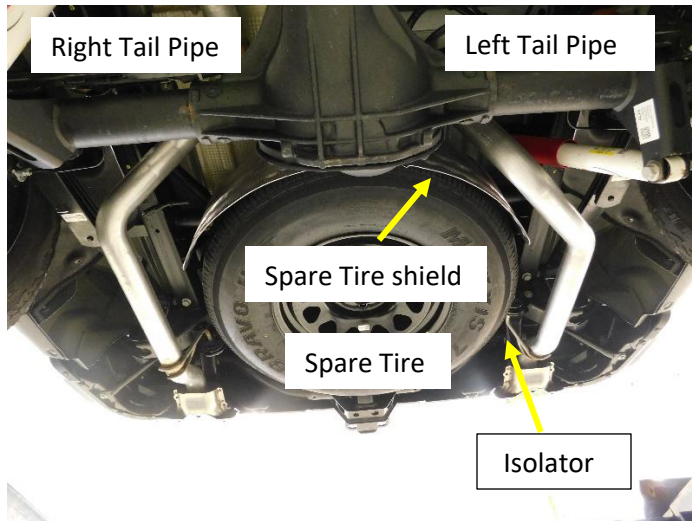


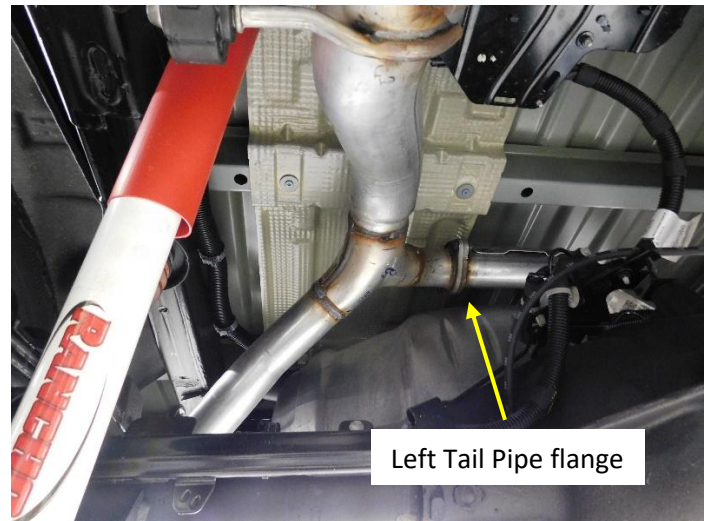
Figure. 2

## Removing the OEM Muffler Assembly Cont'd

5. Remove the spare tire and (x6) bolts on the spare tire shield. **Fig.3**
6. Support the exhaust.
7. Remove the 15mm bolt from the left tail pipe isolator and remove the isolator. **Fig.3**
8. Remove the (x2) 13mm nuts at the flanged connection directly over the differential and remove the left tail pipe. **Fig.4**

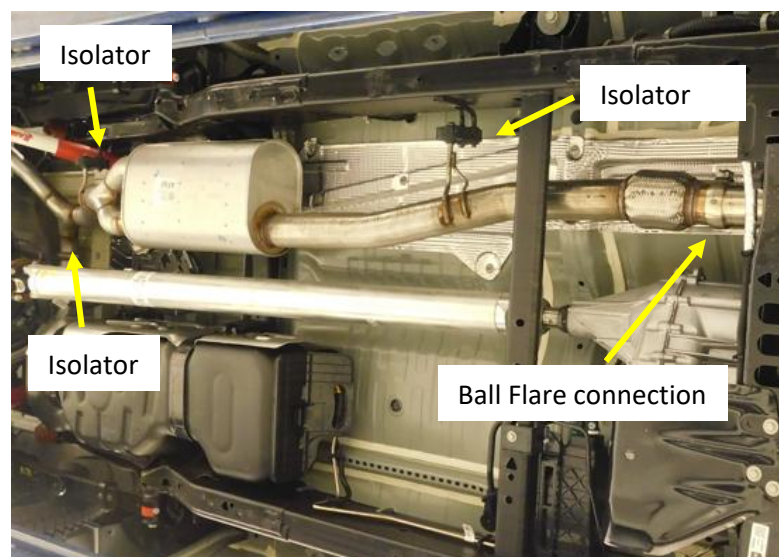


**Figure.3**



**Figure.4**

9. Loosen the band clamp at the ball flare connection on the muffler Inlet pipe. **Fig.5**
10. Spray the isolators with spray lube and remove the hanger isolators at the rear of the muffler and the single isolator at muffler inlet pipe. **Fig.5**
11. Remove the muffler assembly by pushing the assembly rearward over the differential until the inlet pipe clears the crossmember, lower the inlet pipe below the cross member and push the assembly forward again until the rear section is clear of the differential. **Note: Be careful not to damage the drive shaft while removing the muffler assembly**



**Figure.5**

## Installation of the 818206 Exhaust Installing the Valve actuator

1. Remove the exhaust valve actuator motor from the OEM exhaust by removing the (x3) M10 nuts on top of the motor housing. Remove the actuator and drive spring from the mounting bracket.
2. Remove the following supplied mounting hardware from the supplied hardware pack. **Fig.6**
  - 3) ¼-20 X 1.5" button head cap screws,
  - 3) ½" x ¾" spacers,
  - 3) lock washers,
  - 3) ¼-20 nuts,
3. Install the drive spring on to the Actuator as shown in **Figure.7**

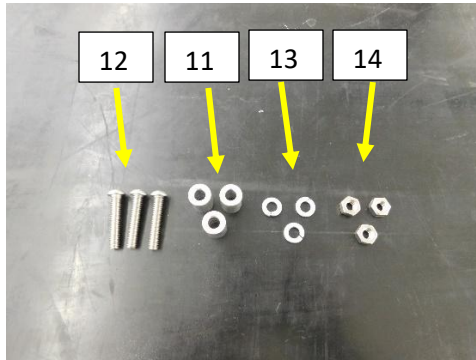


Figure. 6

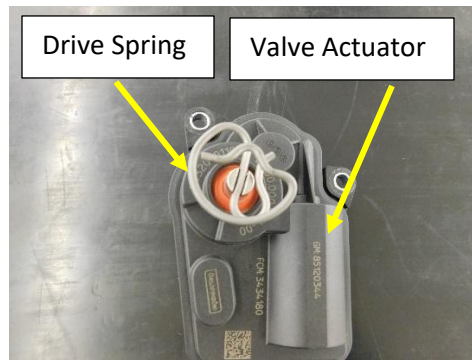


Figure. 7

### Install the actuator and Drive Spring on to the Flowmaster inlet pipe

4. Place the actuator and drive spring assembly on to the mounting plate and align the drive spring curved wire into the slot on the valve shaft. **Fig.9**
5. Turn the actuator's body clockwise slightly until the bolt holes align with the mounting plate. You should feel a small amount of preload as you turn the actuator body – **Do Not Force It**- it should be fairly easy to turn. **Fig.9**
6. Install a spacer between the Actuator body and mounting plate, Align the bolt holes, install a ¼-20 bolt through the actuator and spacer and into the mounting plate. Install a Lock washer and Nut on to the installed bolt and hand tighten. Check that the drive spring is still fully engaged into the valve shaft slot.
7. Install the remaining two bolts, spacers, washers and nuts the same way as the first. **Fig.10**

**Important: Double check the Drive Spring is locked into both the valve shaft and the actuator drive slot.**
8. Tighten the bolts and recheck the drive spring alignment. **Fig. 9/10**



Figure.9



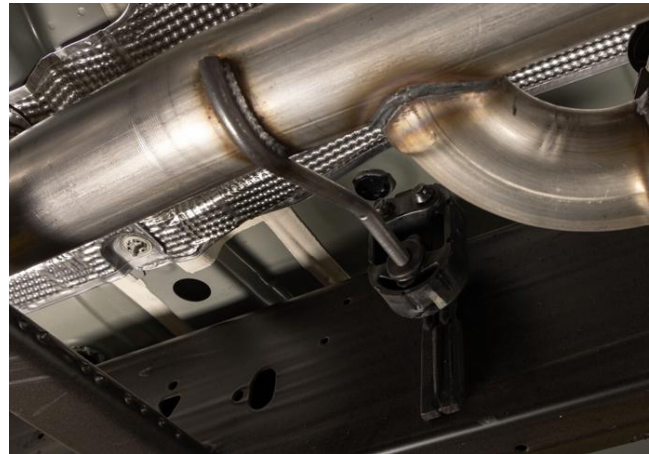
Figure.10

## Installation of the 818206 Exhaust

9. Remove the clamp from the OEM muffler inlet pipe at the ball flare by prying the small clip retainer up and sliding the tang out of the clip.
10. Transfer the ball clamp on to the new Flowmaster muffler inlet pipe with the bolt on the inside and bolt head facing down. **Fig.11**
11. Install the muffler Inlet pipe over the crossmember and on to the ball flare. Align the hanger rod to the isolator bottom hole and insert the hanger rod. **Fig.11/12- Support the muffler inlet pipe with the hanger rod level to the floor.**
12. Position the ball clamp evenly onto the Flowmaster inlet pipe and OEM down pipe. Align the clamp with the bolt on the inside and bolt head facing down for easy access. Push the muffler inlet pipe into the ball socket and tighten the clamp to hold the pipe in place. **Fig.11/12**



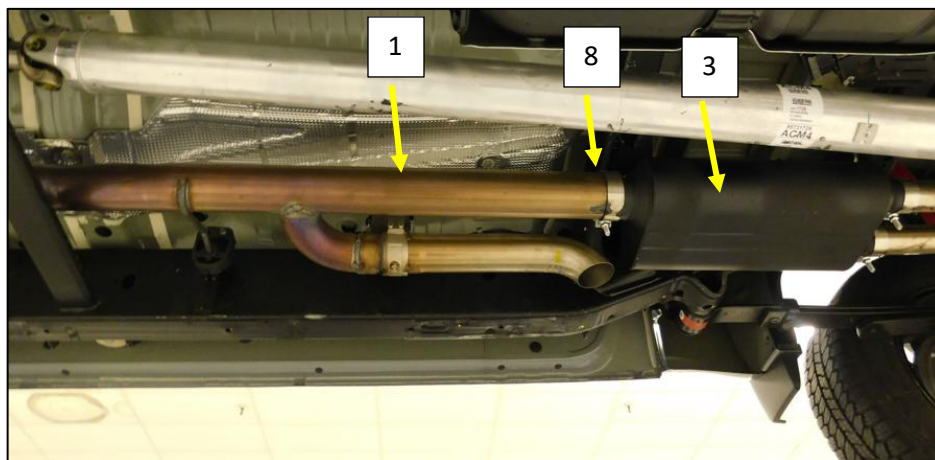
**Figure. 11**



**Figure.12**

13. Install a supplied 3.5" band clamp **(8)** on to the Flowmaster muffler **(3)** Inlet neck.
14. Install the Muffler **(3)** on to the Muffler Inlet pipe **(1)** and tighten the clamp to allow for adjustment.

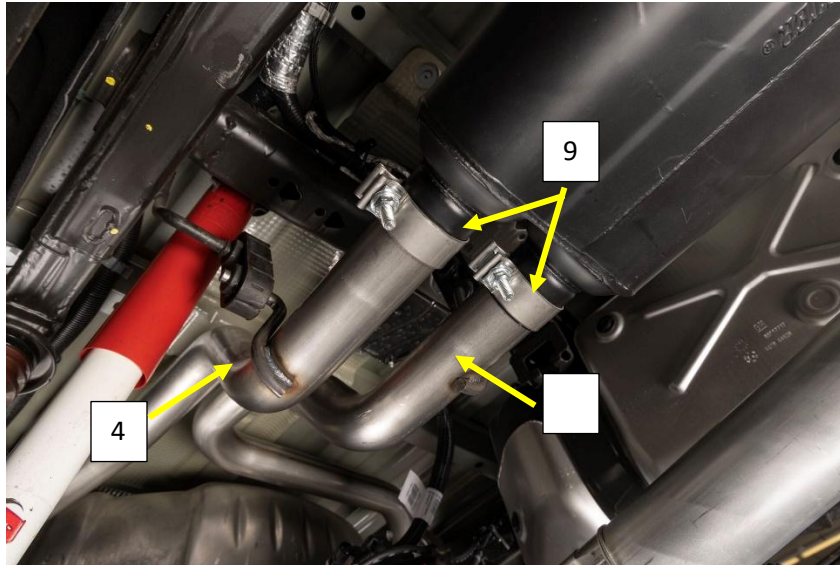
**Note:** Crew Cab trucks with 6.5" bed will use the supplied Muffler extension Pipe **(2)** and additional 3.5" Band Clamp **(8)** between the muffler and inlet pipe.



**Figure.13**

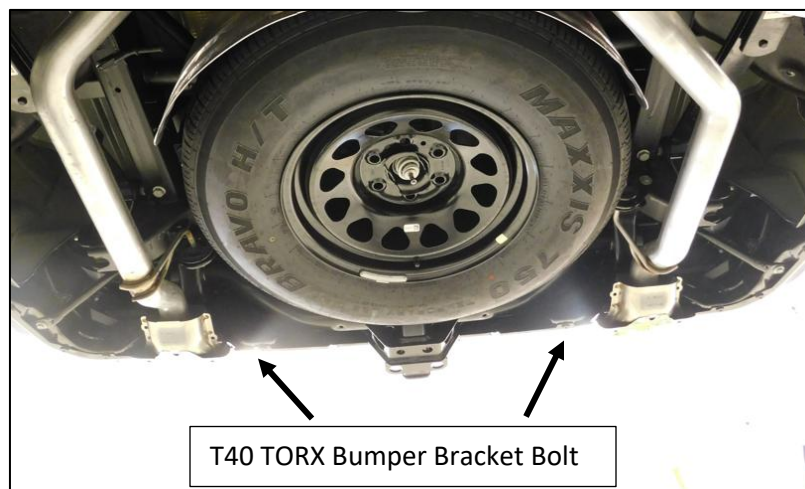
## Installation of the 818206 Exhaust

15. Reinstall the spare tire shield and spare tire.
16. Install a 2.5" Band clamp (9) onto each of the muffler outlets. **Fig.14**
17. Install the Right tail pipe (4) over the axle and into the muffler outlet neck. Rotate the pipe and install the hanger rod into the isolator, Tighten the clamp to allow for adjustment.
18. Install the Left tail pipe (5) over the axle and toward the driver's side of the spare tire. Install the tail pipe into the muffler outlet neck. Rotate the pipe and install the hanger rod into the isolator. , Tighten the clamp to allow for adjustment.



**Figure.14**

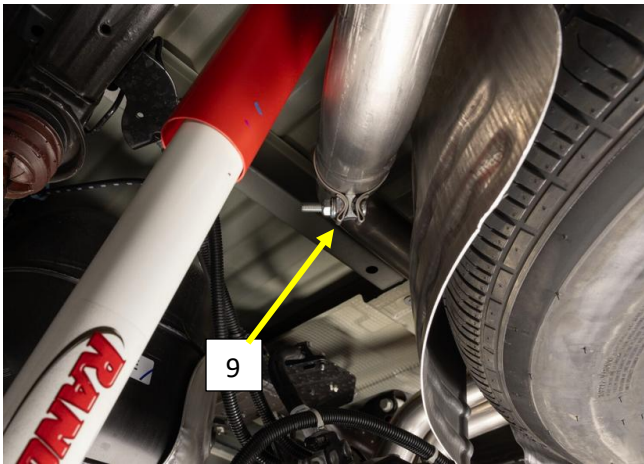
19. Remove the (2) bumper support bracket bolts with a T40 socket shown in Figure.15.
20. Remove the (3) M6 bolts that attach the Exhaust bezels to the bumper by accessing (2) from behind the bumper bracket and the third directly over the opening from the front side.
21. Remove the exhaust bezels



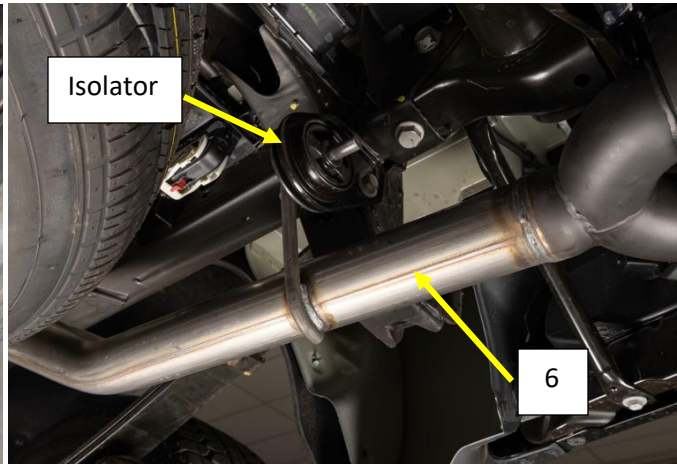
**Figure.15**

## Installation of the 818206 Exhaust

22. Install a 2.5" band clamp (9) onto the expanded and notched end of the Right rear tail pipe (6) with the bolt on the bottom of the pipe and nut facing out. **Fig.16**
23. Install the Right rear tail pipe (6) on to the Right front Tail pipe (4) and tighten the clamp to allow for adjustment. **Fig.17**
24. Install the right rear tail pipe isolator on to the hanger rod and mount the isolator to the frame rail. **Fig.17**

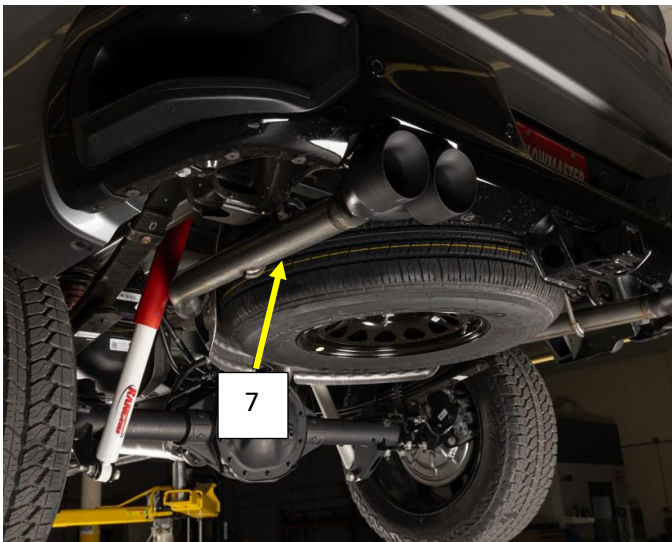


**Figure.16**

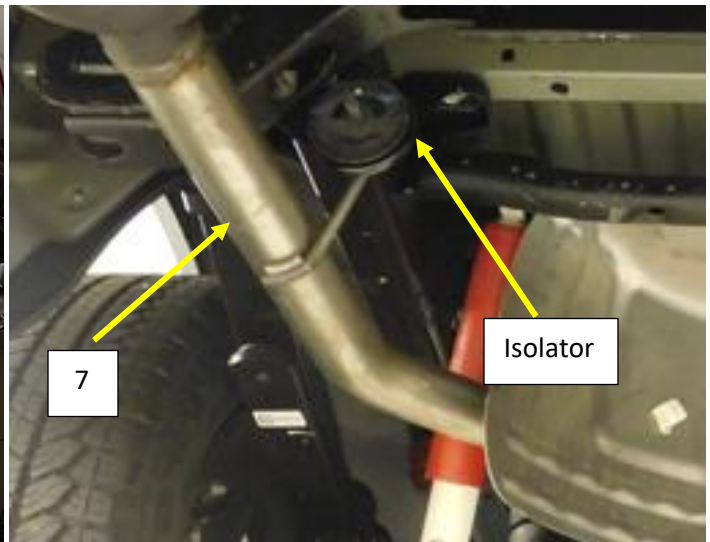


**Figure.17**

25. Install a 2.5" band clamp (9) onto the expanded and notched end of the Left rear tail pipe (7) with the bolt on the bottom of the pipe and nut facing out. **Fig.16**
26. Install the Left Rear tail pipe (7) on to the Left front tail pipe (5) and tighten the clamp to allow for adjustment. **Fig.18**
27. Install the Left rear tail pipe isolator on to the hanger rod and mount the isolator to the frame rail. **Fig.19**



**Figure.18**



**Figure.19**

## Installation of the 818206 Exhaust

28. Install the Valve extension harness (16) into the OEM valve harness and lock the latch. **Fig.20**
29. Run the harness along the top of the frame and up to the exhaust valve actuator. plug the harness into the valve actuator and lock the latch. **Fig.21**
30. Secure the valve extension harness to the OEM wire harness running on top of the frame rail with the Supplied Cable ties. Be sure the valve harness **Can Not** contact any Hot or Moving parts.

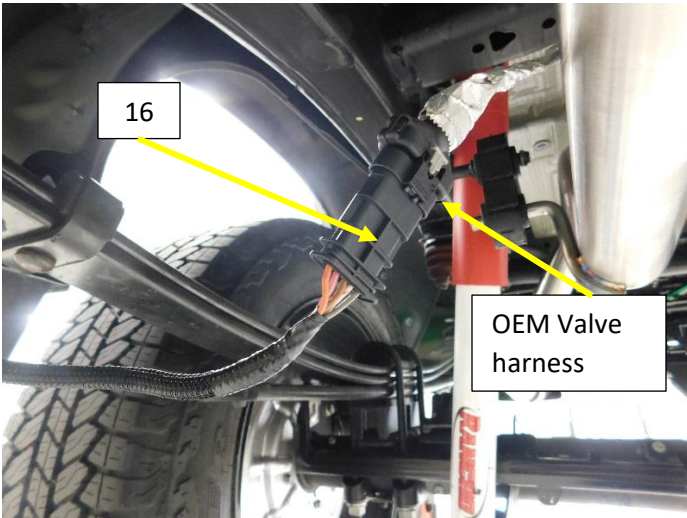


Figure. 20

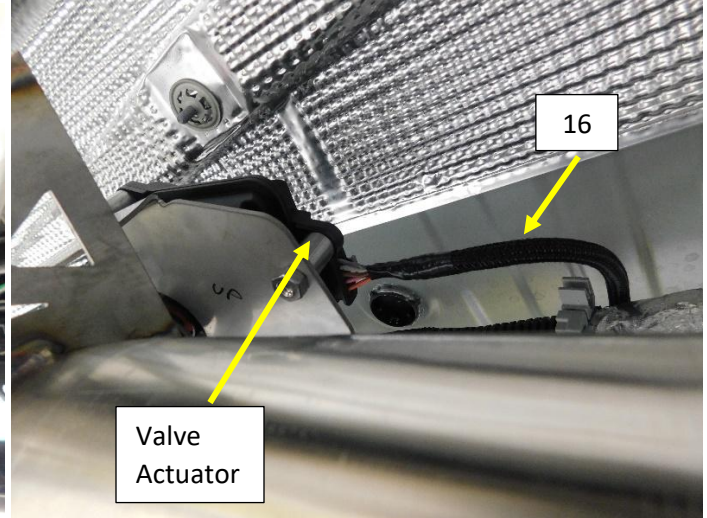


Figure.21

31. Align and tighten the system starting at the front and working your way to the tail pipes, Adjust components for best clearance and alignment. Make several passes over the system and adjust as necessary.
32. The OEM Mode selection switch will control the Flowmaster exhaust valve the same way as the OEM exhaust valve.



**Enjoy your Flowmaster Exhaust!**